

INSTRUCTION

- 1) MARK AND PRE-DRILL 1/8 INCH DIAMETER HOLES IN TEN PLACES ON THE BACK OF THE ARM TRAY AS PER FIGURE#3
- CAUTION: MAXIMUM DRILL DEPTH IS 1/4 INCHES. DO NOT DRILL COMPLETELY THROUGH
- 2) INSTALL HINGES AND SUPPORT BRACKET ON THE BACK OF THE ARM TRAY AS PER FIGURE#4 BY USING SCREW TYPE A
- 3) MARK AND PRE-DRILL HOLE LOCATIONS ON THE ARMREST WALL AT DESIRED HEIGHT
- 4) AFFIX ARM TRAY TO THE ARMREST BY USING SCREW TYPE B
- 5) PRE-DRILL AND INSTALL STOPPER RING AS PER FIGURE#5,6 BY USING SCREW TYPE C

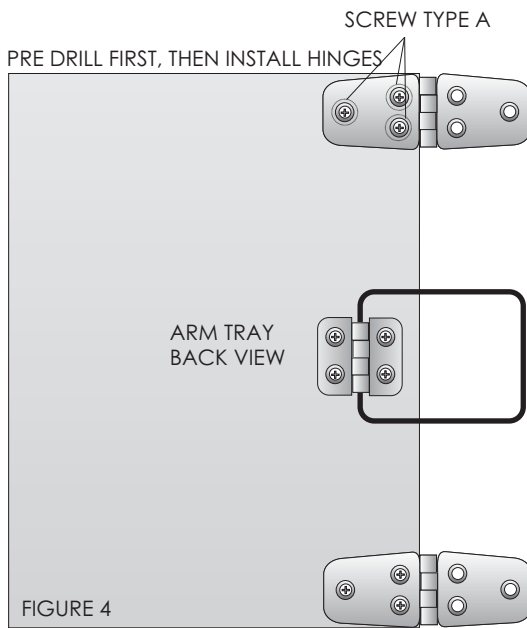
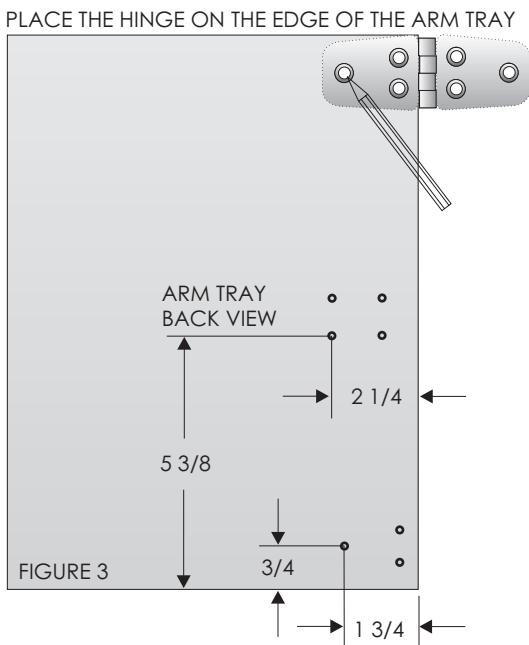
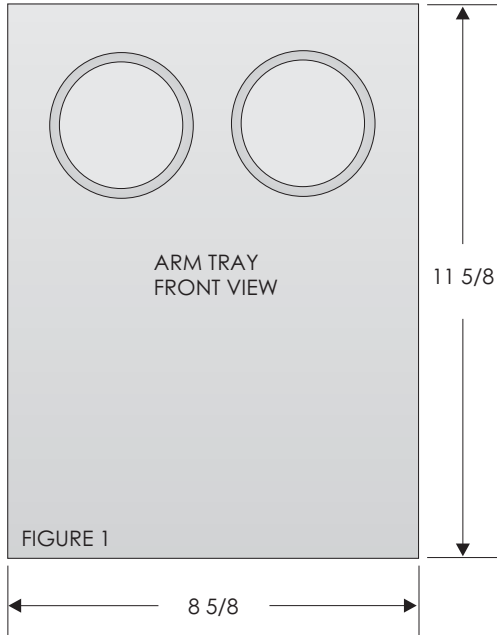

PACKAGE INCLUDES

2 X HINGE

1 X SUPPORT BRACKET

1 X STOPPER RING

X 10

X 6

X 1

SCREW TYPE A
1 / 2 INCH

SCREW TYPE B
5 / 8 INCH

SCREW TYPE C
1 INCH

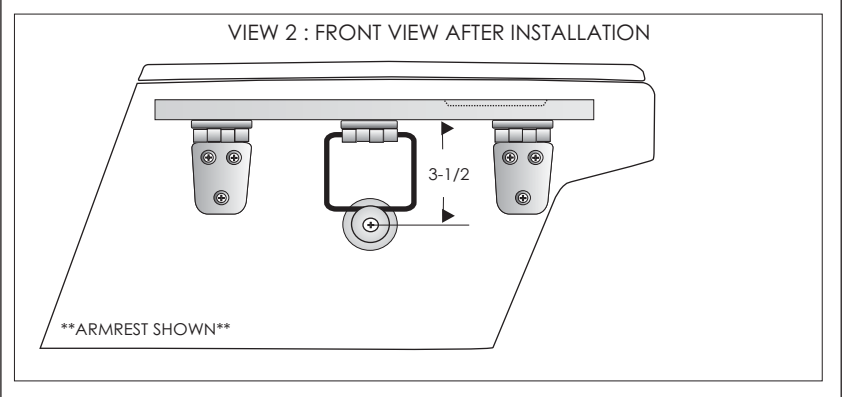
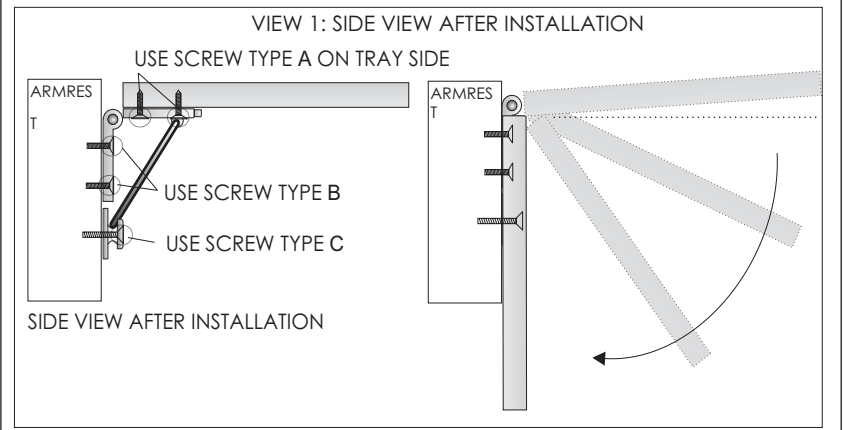

**DIMENSIONS ARE NOT DRAWN TO SCALE
**MEASUREMENTS ARE APPROXIMATE AND SUBJECTED TO NORMAL TOLERANCE