



AG-6000

ZG-Recliner Series

Use & Care Manual

Welcome To

Thank you for purchasing the AG-6000 ZG-Recliner. Before using your chair, please take some time to read the contents of this instruction manual, and for easy enjoyment of this product, please continue to use same as a reference guide.

AG-6000

ZG-Recliner Series

TABLE OF CONTENTS

Safety Instructions	01-02
Chair Components	03
Chair Specifications	04
Chair Dimensions	05
Placing The Chair	06
Chair Installation	07-09
Preparation prior to use	10
Operation Guides	11-13
Maintenance Procedure	14
Troubleshooting	15
Warranty Information	16-19
Warranty Card (Attachment)	

SAFETY INSTRUCTIONS

Please ensure that you read these safety instructions before using your AG 6000 ZG-Recliner.

- This massage chair is intended for use only as described in this manual;
- Whilst assembling the chair components, please ensure that the chair is not connected to any power source
- Once fully assembled and intending to use the chair, please ensure that the power plug of the chair is securely inserted into a properly fitted electrical socket;
- Unplug the chair from the electrical source when not in use or cleaning;
- If the power is cut for any reason, please ensure that the power switch of the chair is in the off position and unplug the chair's power lead from the electrical socket, in order to prevent the risk of short circuit or damage to the chair when the power is restored;
- If you notice any tear to the fabric of the chair and /or any of the chair's internal mechanisms are visible, do not use until you have contacted the Cozzia Servicing Department;
- If the electrical cord of the massage chair is damaged or frayed, it must be replaced by either the manufacturer, the service agent or a qualified electrician;
- Please keep the chair's power cord away from external heat sources;
- Do not wind the power core around the chair itself, as this may cause damage or malfunction;
- Do not use the AG-6000 outdoors or place the chair where it may be exposed to direct sunshine for prolonged periods or place near a heater or where temperatures may reach high levels or where there is high humidity and water vapor such as bathroom;
- Do not attempt to insert any foreign objects into any part of the chair's structure;
- Any tampering with the internal components of this chair may result in electric shock or malfunction;

- Should any liquids be spilled on the chair whilst in operation, please terminate functioning immediately to prevent the risk of short circuiting and resume using the chair only when it is in a clean and dry condition;

- To prevent the risk of injury, do not use the AG-6000 when you yourself are wet and never attempt to plug or unplug the power source with wet hands;

- Close and continuous supervision is necessary should children or disable persons use this chair and the heat function should not be used to alleviate the chance of possible discomfort;

- Do not operate with any of the chair's openings blocked;

- No more than one person at a time should use this massage chair;

- To prevent the risk of injury or damage to the chair do not attempt to sit or stand on the backrest or legrest;

- Should your legs or feet slip from the leg rest during massage, do not attempt to reposition yourself without first pausing your massage program;

- Do not allow children or pets to play on or around the chair;

- Please consult your doctor prior to operation, if you have any doubts about using this chair of if you are pregnant, undergoing medical treatment, using a medical electronic device or are receiving oxygen;

- If you experience pain whilst using this chair, stop use immediately and consult your doctor;

- Do not sue other therapeutic equipment at the same time as you are using this chair;

- This product is not intended for self-treatment of any condition that should be managed by a qualified health care provider.

CHAIR COMPONENTS

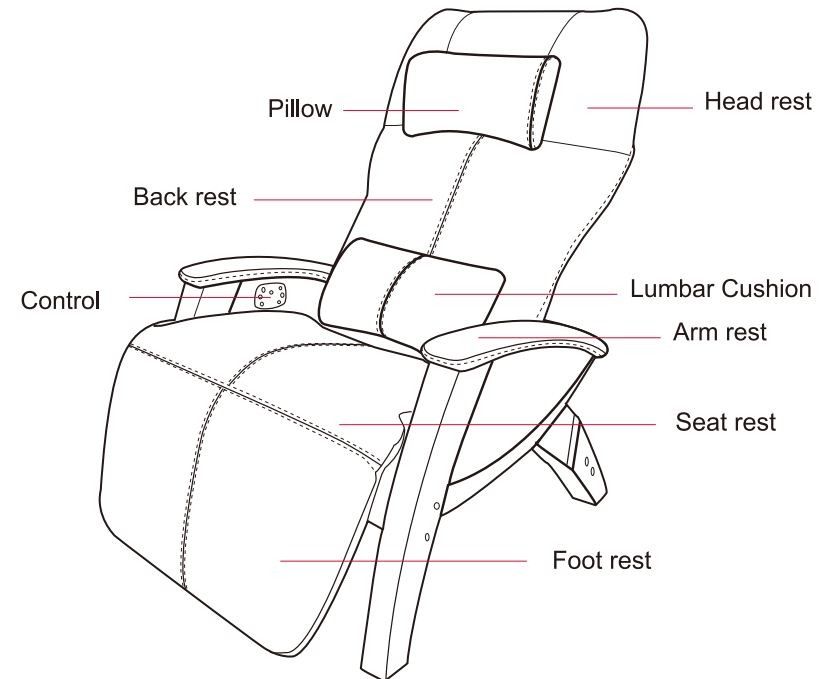

Check the accessories at first

Pillow

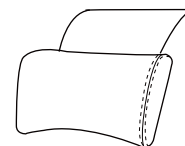

Lumbar Cushion

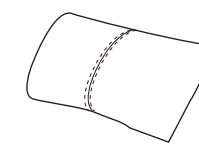

Power Adaptor

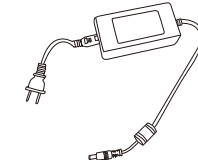

CHAIR SPECIFICATIONS

Specifications		Description
Model No.		AG-6000
Rated Voltage		In-put 110-120V
Rated Frequency		60Hz
Out-put		24VDC 3A
Rated Power Consumption		72W
Auto Timer		15 minutes
Dimensions (L*W*H)		Chair Upright: 43.3"*30.7"*47.5
		Chair Reclined: 63"*30.7"*30"
		Packing Carton:45"*32"*33.9"
Weight	Net Weight	99 lbs
	Gross Weight	117 lbs
Maxium Load Weight		400lbs
Required Recline Clearance		28"
Usage Condition		Environmental temperature 10°C-40°C
		Contrasting humidity level 30-85RH
Storage Condition		Storage temperature 20°C-60°C
		Storage humidity level 30-85RH
Safety Feature		Equipped with overheating and power surge detectors.

CHAIR DIMENSIONS

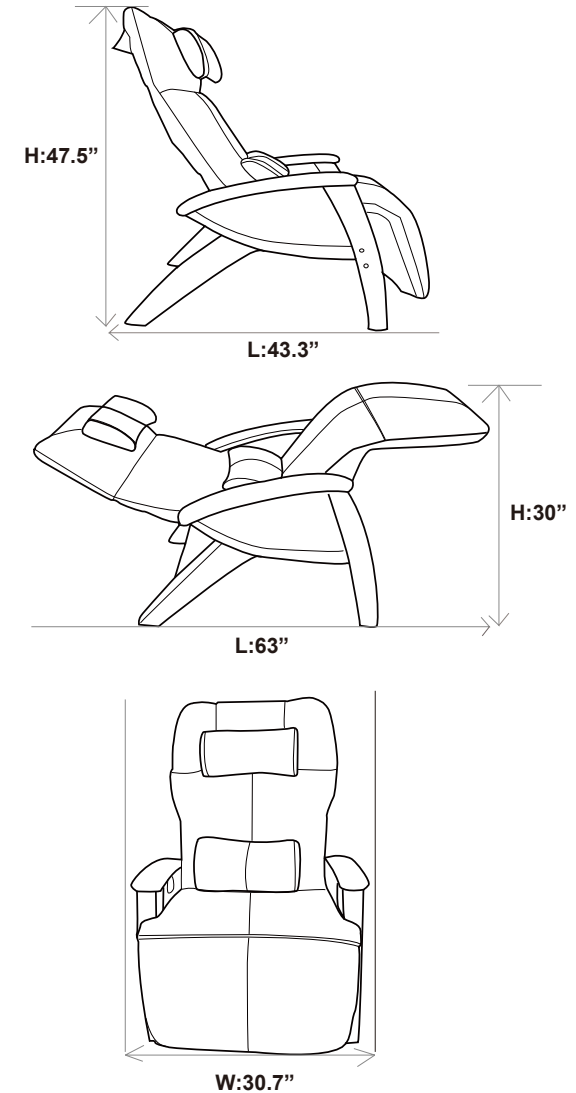

PLACE THE CHAIR

1. Lay a carpet, etc. on the set-up place.

It prevents damaging the floor, and mufes the noise during use.

2. Ensure there is suficient space to allow the chair to recline.

In order not to touch the wall or other things when reclined, allow a clearance of 70cm(28") or more to the front and the back of the chair.

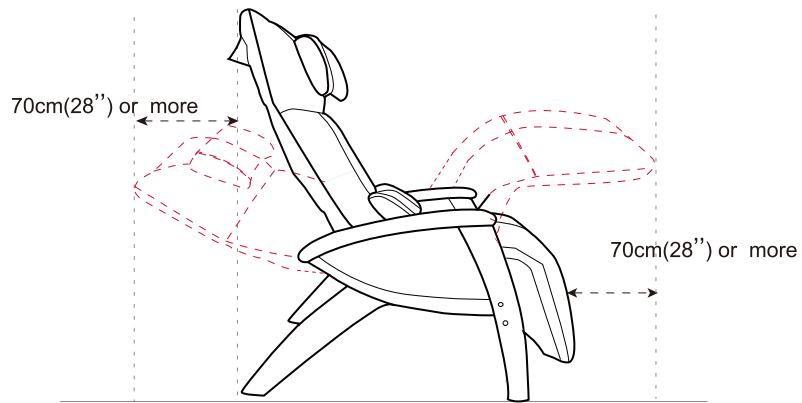

Notes

- Place the chair on a level surface.
- Keep the chair at least 1 meter(3ft) away from AV machines like a TV or radio.
- Do not keep the chair in a place with high humidity like a bathroom.
- Do not keep the chair in a place where it will be exposed to direct sunshine for an extended period, or in a place near a heater where the temperature may reaches high levels.

CHAIR INSTALLATION

• Step 1:

- Unfold the backrest frame, fix the "L" shaped latch on the both sides, the attach then rear fabric cover by Velcro;

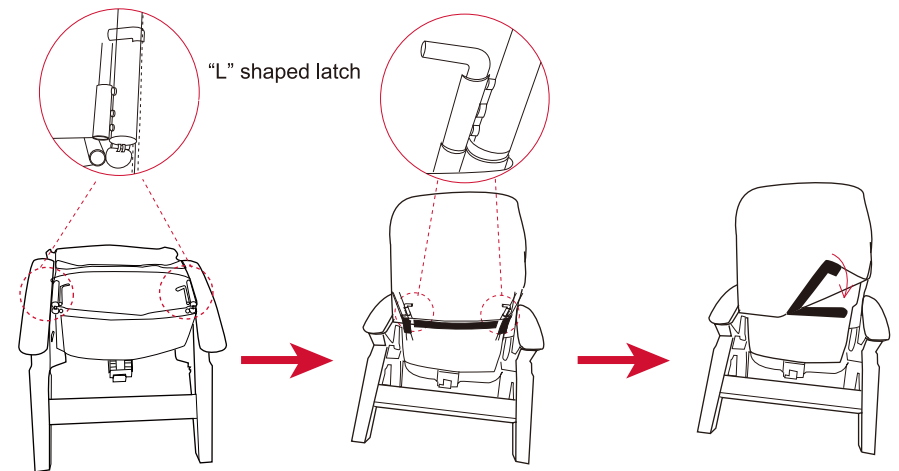

• Step 2:

- Push the headrest frame forward, unzip the zipper of the back cover to the end, then pull up the pad and put it onto the headrest frame.
 - And to ensure the pad set can be well addressed, without any damage, need your attention to below notes:
 - As backrest pad is one peace from head to feet, before putting on the pad set, please check and ensure the feet and seat part are already tightly attached;
 - Make sure the back cover is thoroughly unzipped before dressing the pad;
- Don't pull up too high and too strongly.*

Head rest frame

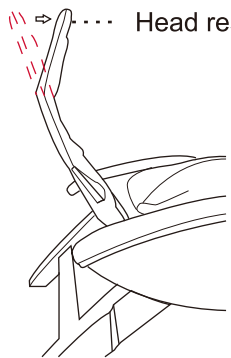

Back pad



•Step 3:

- Zip up the fastener of the rear cover of the back pad;

Fastener

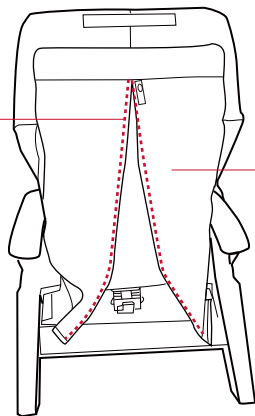

Rear cover of back pad

•Step 4:

- Tidy and attach the seat pad by the Velcro.

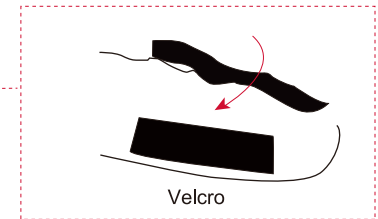
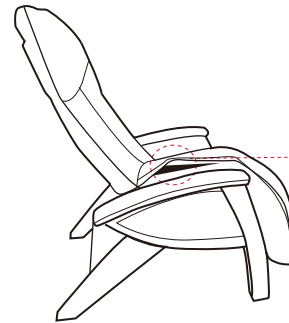

•Step 5:

- Attach the pillow to the Velcro on the headrest;

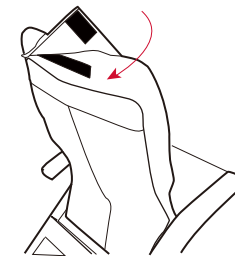

•Step 6:

- Place the lumbar cushion on the seat.

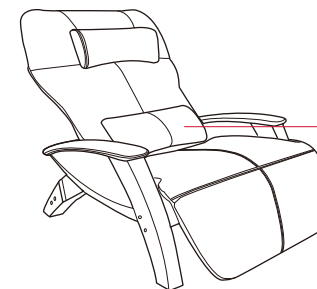

Lumbar cushion

PREPARATION PRIOR TO USE

1. Check the cloth of the chair

Prior to use, be sure to check that the cover cloth or the cloth of other parts is not torn. If a tear is found, stop using the chair immediately, unplug the power source, and obtain service. If the chair is used with torn cloth, it may result in injury or electric shock.

2. Check the power cord

Check that there is neither breakage or damage to the power adaptor. Check that the cords are not caught or placed beneath the chair.

3. How to connect the power source.

- 1) Connect the power adaptor with the chair.
- 2) Insert the power plug into an outlet.

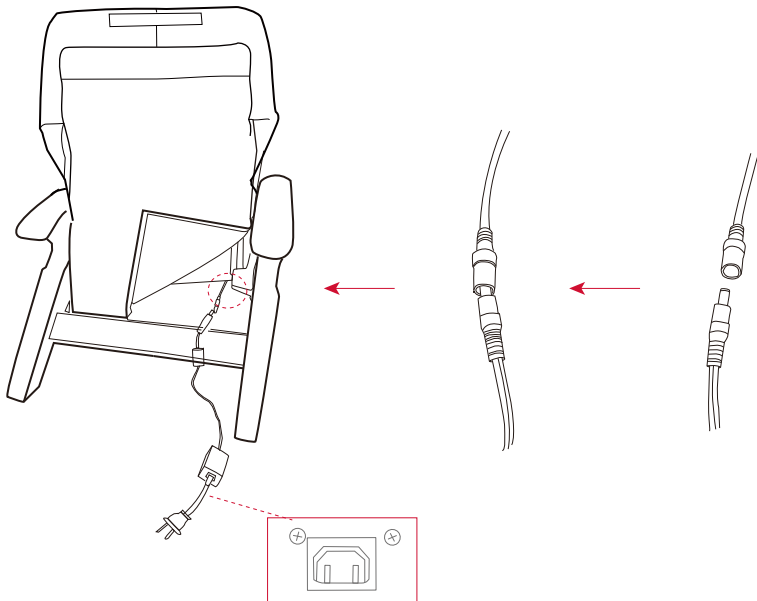

OPERATION GUIDES

Control Panel

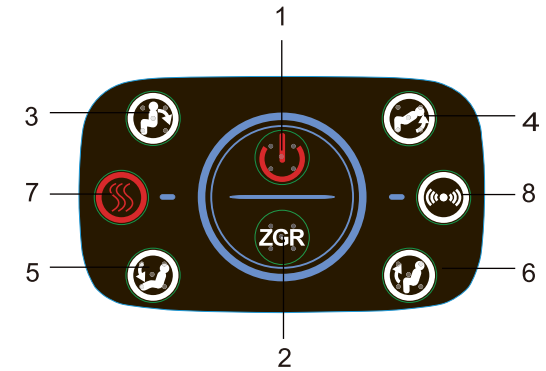

1. On/Off button:

- On pressing the On/Off button, a light will tell you that the chair is in the idle functioning mode and will commence a massage program when you press any other function button. If during a massage function program, should you wish to suspend same for any reason, please press the On/Off button and the program will cease;

2.ZGR button:

- On pressing the ZGR button the back rest, the foot rests and the seat are automatically adjusted to preset reclining angles.
- The reclining motion can be stopped by pressing either the ZGR button, the Back Rest Recline/Restore button or the Leg Rest Raise/Restore button;
- When the reclining motion is stopped by pressing either of these buttons and not the On/Off button, you can resume the motion by pressing the button again;
- After achieving the ZGR position, you may still adjust the angles of the backrest (incline only) and footrest by pressing the relevant button;

3/4.Back Rest–Recline/Restore:

- Press this button to activate the backrest and press again when the backrest is at your desired angle. The angle of the seat will be changed automatically to accord with the angle of the backrest. Movement of the back rest can be stopped by pressing the Back Rest Recline/Raise button again or the ZGR button. When activating the backrest, the chair will not simultaneously respond to the Leg rest Recline/Restore action, Heating and Vibration functions.

5/6.Leg Rest–Raise/Restore:

- Press this button to activate the Leg Rest–Raise/Restore action and press again when the leg rest is at your desired angle. Movement of the leg rest can be stopped by pressing the Leg Rest–Raise/Restore button again or the ZGR button. When activating the leg rest, the chair will not respond simultaneously to Back Rest Recline/Restore action or the Heating and Vibration functions.

7.Heating:

- Press this button to commence the heating function for the lumbar and seat region. A light will indicate that the heating function is in operation. Press the button again to cease the function. With the heating function in operation, should you wish to change the angle of the back rest or leg rest, the heating function will pause and resume automatically once the back rest or leg rest action is completed.

8.Vibration:

- Press this button to activate the vibration function for the lower back and lumbar areas. The vibration function operates in a sequence of ‘strong’ – ‘weak’ – ‘off’ . Press the button again to change the sequence. With the vibration function in operation, should you wish to change the angle of the back rest or leg rest, the vibration function will pause and resume automatically on the back rest or leg rest action is completed.

Automatic Timer

- The chair is programmed to operate for a period of fifteen minutes, after which all functions will stop and the chair will adopt an idle mode in its current position. To resume use of the chair after this period, simply press your desired function button.

After Use

- On conclusion of your massage program, please ensure that you return the back rest and foot rest to their starting positions and turn off the power.

MAINTENANCE PROCEDURE

WARNING

Be sure to disconnect the power plug from the outlet prior to maintenance

NOTE

Do not attempt to use benzene. Thinner alcohol ,alkaline detergent or bleaching agent for cleaning,as this may result in deformation, discoloration or cracking.

HEAD REST, BACK PAD, SEAT COVER, ARM REST, FOOT REST, PILLOW(LEATHER)

Perform daily maintenance by wiping with a soft dry cloth. When parts are badly soiled, adopt the following maintenance procedure.

1. Soak a soft cloth in diluted neutral kitchen detergent and squeeze it well. Wipe the main unit with the damp cloth in a tapping motion.
2. Soak a cloth in clean water, and squeeze it well. Wipe of the remaining detergent with the damp cloth.
3. Wipe it with a dry cloth afterwards.
 - Do not force-dry with a drier.
 - Do not force contact with vinyl products for an extended period. It may cause discoloration.

NOTES

- Leather is a natural material, so imperfections grain, dye variations and natural markings do not constitute a defect.
- Polyurethane foam padding tends to soften and light creases may form on the leather cover over a period of three months. These are natural occurrences and do not require any type of maintenance.
- A professional cleaner should be contacted for particular types of stains such as ink marks.

MAIN UNIT (Wooden chair foot , frame and the control panel)

Impossible to recline. Impossible to raise or lower the foot rest. Remove the obstruction. Check that there is no obstruction. This phenomenon is caused by the timer, but not a problem. The chair stops in the middle of operation. Operation failure Well connect the DC terminals between the chair and power adaptor. Check that the power adaptor is well connected to the chair. Push the power plug into the outlet securely. Check that the power plug is securely plugged into the outlet. Countermeasures Check points Type of Troubles Wipe with a soft dry cloth. Do not wipe with a damp cloth.

TROUBLESHOOTING

WARNING

If the trouble still persists after following the proper countermeasures,stop using the chair to avoid possible accidents. Disconnect the power plug from the outlet and consult Cozzia customer service Dept.. Do not attempt to repair the chair, instead contact a certified technician.

Type of Troubles	Check points	Countermeasures
Operation failure	Check that the power plug is securely plugged into the outlet	Push the power plug into the outlet securely
	Check that the power adaptor is well connected to the chair	Well connect the DC terminals between the chair and power adaptor
The chair stops in the middle of operation	This phenomenon is caused by the timer but not a problem	
Impossible to recline Impossible to raise or lower the foot rest	Check that there is no obstruction	Remove the obstruction

If you continue to have problems, please read the warranty card and contact the Cozzia service department.

WARRANTY INFORMATION

COZZIA products have the following warranty:

COZZIA's massage chairs, massaging motion upholstery and home theater massage seating provide a one year in-home service warranty and a two-year parts warranty.

COZZIA customer service will not issue Return Material Authorizations (RMAs) for products.

COZZIA products will be either repaired by the consumer or by an in-home technician.

COZZIA will not issue Return Material Authorizations (RMAs) for buyer's remorse.

Service and Technical Support

Consumers may contact Cozzia's Customer Service Department at 1-877-977-0656 between 9.00am and 5.00pm PST, Monday thru Friday or e-mail us at Service@cozziausa.com or visit our website at www.cozziausa.com for warranty and service issues.

Consumers are required to provide the unit serial number and dated proof of purchase (sales receipt) when they contact the Cozzia Service Department regarding repair.

A Cozzia customer service representative will attend to most consumer inquiries, but in some cases a technical service specialist will be required to provide enhanced support.

Non warranty repair is provided on a 'per incident' basis. Cozzia customer service will verify that the unit has failed and provide instructions for repair. All applicable repairs, parts, shipping, handling, local tax and a 'per incident' fee will be charged for non-warranty repairs and support calls

Proof of purchase (original receipt) is required for all warranty repairs and servicing.

Extended Warranties

Cozzia offers extended warranty programs to enhance ownership of Cozzia products. Extended warranty provides a three year limited repair or replacement massage chair warranty with on-site service. Please visit www.cozziausa.com for the latest terms and pricing regarding extended warranties.

Product Repairs: Many Cozzia product repairs may be performed by the consumer in his/her own home with parts and instructions supplied by Cozzia, such as a remote controller replacement that does not require the services of a technician.

- Floor models and Demonstration units have a pro-rated warranty period that begins the day the model is placed on the floor and connected to an electrical outlet by the retail partner. Proof of purchase is required to obtain warranty service and parts. Non-warranty parts and servicing are available at a 'per incident' charge;
- Warranty Coverage Period: Warranty coverage starts at the time the consumer purchases their chair. Proof of purchase is required for all warranty repairs. The warranty time period is measured by continuous calendar days based on the seven day week.
- Field Service: Cozzia Customer Service Department will diagnose and schedule an authorized service provider to repair the chair in the consumer's residence;
- Parts: All parts deemed necessary for repairs will be shipped to the consumer at no charge by the Cozzia Service Department.

Consumer Warranty Limitations and Exclusions

Warranties are only valid in the 48 contiguous United States, and are contingent upon the consumer operating the chair according to the corresponding instruction manual.

- The warranty only applied to Cozzia products and does not include any accessories enhancements;
- Field service requires pre-approval and must be performed by Cozzia's authorized field service personnel. Field service is only available in the 48 contiguous United States;
- Softening of foam and filling composites in pillows, pads and memory foam occurs naturally and does not constitute a defect under this warranty;
- Fading, wear and piling of fabric occurs naturally and does not constitute a defect under this warranty;
- Warranty do not cover any loss or damage resulting from improper installation, unauthorized repairs or modifications, improper use of the electrical/power supply, a malfunction or damage of an operating part from failure to implement the manufacturer' s recommended maintenance, transportation damage, theft, abuse, misuse, neglect, vandalism, or environmental conditions (fire, flood, rust, corrosion, sand, dirt, windstorm, hail, earthquake or exposure to weather conditions), loss of use during any period that the product is at a repair facility or is otherwise awaiting parts or repair;
- Damage due to shipping and handling does not constitute a defect under this warranty;
- Under no circumstances Shall Cozzia or its representatives be liable for indirect consequential or incidental damages (including damages for lost profits, business interruption, bodily injury, medical problems) even if the other party has been advised of the possibility of such damages or possible problems;

- Warranties are non-transferable and shall be lieu of any other warranty express or implied, including but not limited to any implied warranty or merchantability of fitness for particular use;
- Cozzia's sole liability and the purchaser's exclusive remedy shall be for repair, or at Cozzia's option, for replacement of the defective part. Notwithstanding the above, if the replacement parts for defective materials are not available, Cozzia reserves the right to make substitutions in lieu of repair or replacement;
- All warranties begin on the date of purchase and no allowance or extension is offered for delivery and/or installation;
- Warranties do not apply to rental businesses, commercial institutions or other non-residential users.