

ANS™
WAVERLY
PEDISPA

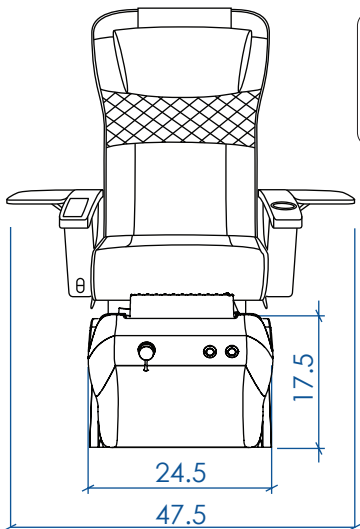

Package weight: 89 lbs.
Tub w/ floor installation: 77 lbs.
Sink Bowl Capacity: 4.5 U.S. gallon (17.03L)

Weight capacity: 300lbs



Front view

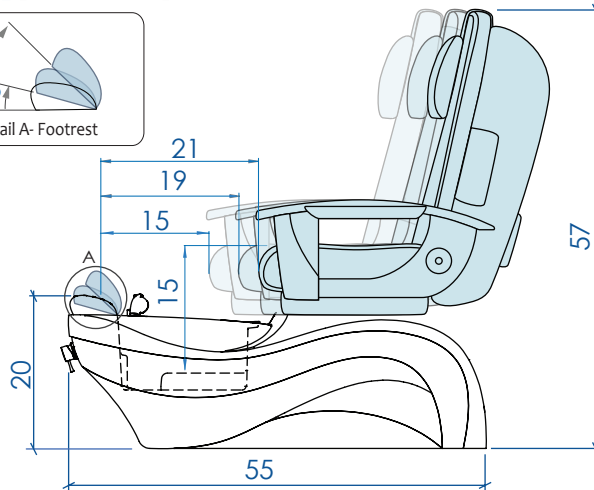
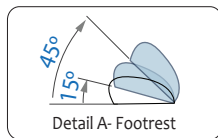

Side view

PARTS IDENTIFICATION

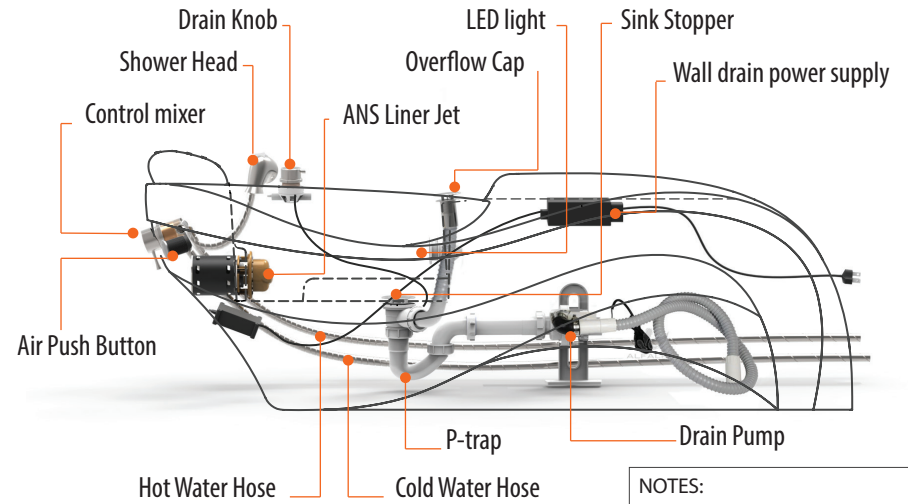

NOTES:
POWER SOURCE: 110V AC/15 AMP 60 HZ (GFI PROTECTED)
CONFORMS TO
UL STD 1795 AND UL STD 73
CERTIFIED TO CSA C 22.2 NO. 218.1
AND CAN/CSA C 22.2 NO. 68

Note: The wall drain system is shown in the above diagram

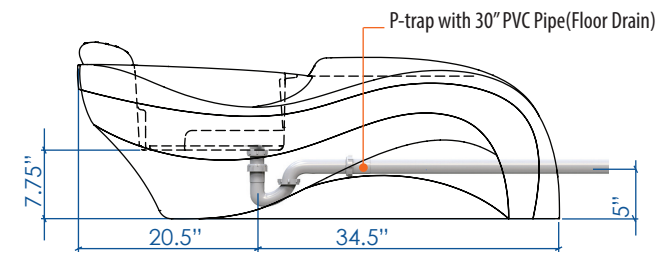
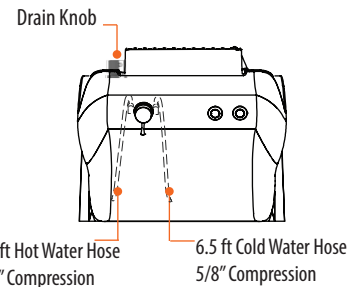

Wall Drain: Flex drain pipe extended 2ft from the back of the basin

Floor Drain: Drain pipe & bushing extended 3" from the back of the basin

Wall Drain

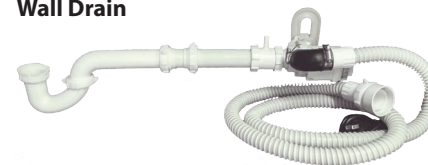

1-5/16" discharge hose after pump with 1-1/2" bushing
Drain pump - 120V AC, 85W, 60Hz, 1 Amp

Floor Drain



Drain Pipe - 1-1/2" PVC extendable ~5" above floor